

客戶名稱 CUSTOMERS:			
日期 DATE:			
產品名稱 PRODUCT:	Cement Resistors (SQM Series) 水泥電阻器		
物料代號 PART NO.:	Customer	版本 REV.:	V11.04
	Queen Mao	CM□□W-SQM-□□□□R□	

規格承認書 APPROVAL SHEET



客戶承認簽印 CUSTOMER APPROVED BY	核准 APPROVE	主管 CHIEF	承辦 RESPONSIBLE
APPROVED NO.:	ECN.:	/	/
MODEL:		/	/
CUSTOMER P/N:		/	/



昆 貿 電 子 股 份 有 限 公 司
QUEEN MAO ELECTRONIC CO., LTD.

22178 新 北 市 汐 止 區 大 安 街 56 巷 35 號
 No. 35, LANE 56, DA'AN STREET, XIZHI DISTRICT, NEW TAIPEI CITY 22178, TAIWAN (R.O.C.)

TEL: 886-2-8648-5566 FAX: 886-2-8648-0538

E-mail: service@queenmao.com.tw

URL: <http://www.queenmao.com.tw>



1. 一般事項 General

1.1 適用範圍 Scope

本承認書適用於[水泥電阻器]。

This specification covers Cement Resistors.

1.2 品質 Quality

本電阻器的製造係經高品質管理程序，並具有高信賴性的品質保證，且符合 RoHS 和無鹵要求。

The resistor is manufactured by highly quality-controlled process and guaranteed high reliability, it meets RoHS & Halogen-Free requirement.

1.3 標準試驗狀態 Standard measuring conditions

溫度 20±2°C、濕度 65±5%。

但在溫度 5~35°C、濕度 45~85%之情況下，仍可給予判定。

Temperature 20±2°C, Humidity 65±5%.

Being no doubt about the judgment, measurements can be made within the following Temperature 5~35°C, Humidity 45~85%.

1.4 形名 (例) Type designation (example)

依使用種類、額定電力、形狀、公稱電阻值、電阻值容許差而區別，其構造如下：
The type designation shall be in the following form and as specified.

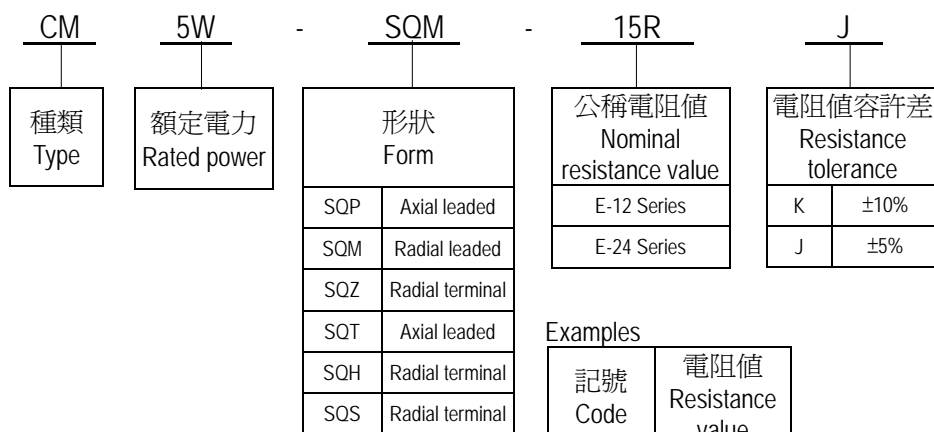



1.5 額定電力 Rated power

額定電力係適應在周圍溫度 70°C 可以連續負載的最大電力，如表-1；但周圍溫度如超過 70°C 時之額定電力則依圖一的電力輕減曲線實施。

Rated power is maximum power which can be continuously loaded at specified ambient temperature 70°C, however when the ambient temperature exceeds 70°C, rated power should be determined from the derating curve of Fig.1.

表-1 Table-1

額定電力 Rated power	最高使用電壓 Maximum working voltage	最高過負荷電壓 Maximum overload voltage	使用溫度範圍 Operating temperature range
2W	150V	300V	-55°C ~ 155°C
3W	350V	700V	
5W	350V	700V	
7W	500V	1000V	
10W	750V	1500V	

圖一 電力輕減曲線

Figure 1 Power derating curve

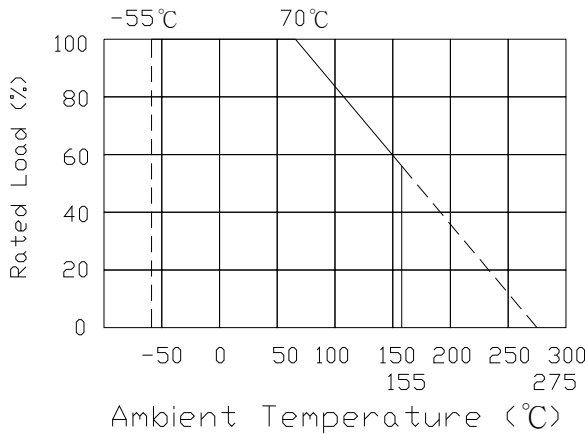

圖二 表面溫度上昇

Figure 2 Surface temperature rise

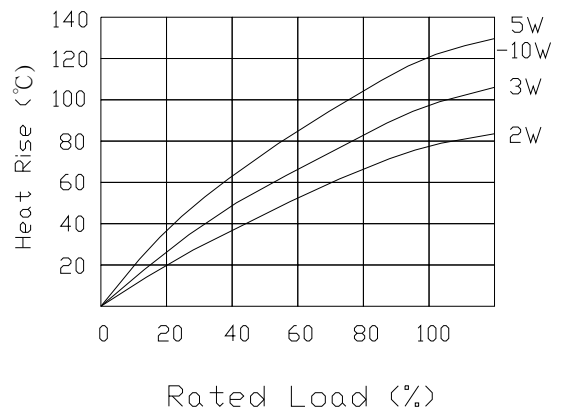



1.6 額定電壓 Rated voltage

額定電壓係指對應於額定電力的直流或交流（商用頻率之有效值）的電壓，由下式求得。但所求得之額定電壓超過表一所示之最高使用電壓時則以最高使用電壓為額定電壓。

The rated voltage shall be the D.C. or A.C. (R.M.S. at power frequency) voltage which corresponds the rated power and the value of which is calculated from the formula below. If the rated voltage exceeds the maximum voltage, the maximum voltage will apply.

$$E = \sqrt{P \cdot R}$$

Where E：額定電壓 Rated voltage (V)

P：額定電力 Rated power (W)

R：公稱電阻值 Norminal resistance (Ω)

1.7 公稱電阻值 Nominal resistance values

公稱電阻值係按表-2 之數乘以 10^n (n 為整數)之數值，其單位為歐姆(Ω)。公稱電阻值之範圍則按表-1 所示。

The nominal resistance values shall be the numerical values given in Table-2 multiplied by 10^n (n is an integer) in the unit of ohm(Ω).

The minimum resistance and maximum resistance shall be as given in Table-1.

表-2 電阻值有效數字的標準 Table-2 Standard nominal resistance values

系列名 Name of series	標準公稱電阻值 (為有效數字，單位省略) Standard nominal resistance values (significant figures with the unit omitted)
E-6	1.0, 1.5, 2.2, 3.3, 4.7, 6.8
E-12	1.0, 1.2, 1.5, 1.8, 2.2, 2.7, 3.3, 3.9, 4.7, 5.6, 6.8, 8.2
E-24	1.0, 1.1, 1.2, 1.3, 1.5, 1.6, 1.8, 2.0, 2.2, 2.4, 2.7, 3.0, 3.3, 3.6, 3.9, 4.3, 4.7, 5.1, 5.6, 6.2, 6.8, 7.5, 8.2, 9.1



2. 構造 Construction

2.1 外形寸法 External dimensions

參照本仕様書の「5. 外形寸法」。

The dimensions shall be satisfied with 「5. External dimensions」.

2.2 構造圖 Structure diagram

CM 系列之水泥電阻器係按下表的材料而構成：

The construction of resistor (CM series) shall be as follows：

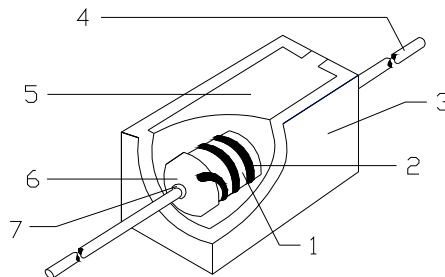

號碼 No.	構造名稱 Item	內容 Material
1	基體磁器 Ceramic core	使用高含鋁量的瓷器棒。 High alumina ceramic is used.
2	電阻體 Resistance element	電阻體的成份係使用具耐熱性之鎳合金抵抗線或耐功率皮膜。 The resistor element consists of heat resistant wire of nickel alloy or power film.
3	瓷殼 Ceramic case	使用高熱傳導性瓷殼。 High thermal conductive ceramic case.
4	導線 Lead wire	焊錫或鍍錫的軟銅線。 Soldered or tinned annealed copper wire.
5	充填材料 Enclosing material	使用特殊不燃性耐熱水泥塗料。 Special non-flame cement.
6	端子 Terminal	鐵帽。 Tinned iron cap.
7	連接 Connection	導線對鐵帽須以電氣熔接。 The lead wire, which is plated with solder, shall be mounted to the caps by welding process.



CEMENT RESISTORS
水泥電阻器

2.3 鐵帽端子 Terminal caps

鐵帽端子須確實地連接(電氣的及機械的)於電阻體上。

The caps shall be securely connected with the resistor element electrically and mechanically.

2.4 表示 Indication

此標誌能夠承受自然及電子退化的要求，它是永久的標誌。

The stamp shall resist physical or electrical deterioration, it is permanent marking.

例 Example :

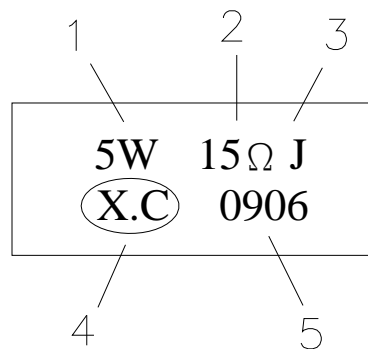

1 功 率 Rated power

2 電阻值 Resistance

3 電阻值容許差 Resistance tolerance

4 製造者名 Manufacturer

5 製造日期 Manufacturing date

如何判讀製造日期。

How to read the manufacturing date.

例 Example :

09 06
A B

A : 表示年份為 2009 年。

Represents the year 2009.

B : 表示週期為第 6 週。

Represents the 6th week.



3. 特性 Characteristics

表-3 Table-3

項目 Item	規格值 Performance	試驗方法 (依據 JIS C 5202) Test methods (Conform to JIS C 5202)
溫度係數 Temperature coefficient	<p>< 20Ω ±400PPM/°C 以內。 ≥ 20Ω ±300PPM/°C 以內。</p> <p>< 20Ω within ±400PPM/°C ≥ 20Ω within ±300PPM/°C</p>	<p>5.2 項參照 Comply with 5.2</p> $\frac{R_1 - R_0}{R_0(T_1 - T_0)} \times 10^6 \text{ (PPM/°C)}$ <p>R₀:室溫(T₀)所測量之電阻值。 R₁:室溫+100°C(T₁)後所測量之電阻值。 R₀: Resistance value at room temp. (T₀). R₁: Resistance value at room temp. plus 100°C (T₁).</p>
短時間過負荷 Short time overload	<p>±(2%+0.05Ω)以內。 不得有機械的損傷。 within ±(2%+0.05Ω) No evidence of mechanical damage.</p>	<p>5.5 項參照 Comply with 5.5</p> <p>繞線：額定電力的 10 倍, 5 秒。 Wire wound: 10 times of rated wattage for 5 seconds</p> <p>耐功率皮膜：額定電壓 X 2.5 倍, 5 秒。 Power film: Rated voltage X 2.5 times, 5s</p>
絕緣抵抗 Insulation resistance	<p>10³MΩ 以上。 10³MΩ or more</p>	<p>5.6 項參照 Comply with 5.6</p> <p>置於 V 型槽方法。 施加直流電壓 500V 60 秒。 V-block method Resistor shall be tested at DC 500V for 60 seconds.</p>
耐電壓 Dielectric withstanding voltage	<p>無電弧放電、燒損及絕緣破壞等異狀。 No evidence of flashover mechanical damage, arcing or insulation breakdown.</p>	<p>5.7 項參照 Comply with 5.7</p> <p>常壓,置於 V 型槽方法。 施加交流電壓 1000V 60 秒。 Constant pressure, V-block method Resistor shall be tested at AC 1000V for 60 seconds.</p>
斷續過負荷 Pulse overload	<p>±(2%+0.05Ω)以內。 within±(2%+0.05Ω)</p>	<p>5.8 項參照 Comply with 5.8</p> <p>額定電壓 X 4 倍, 10000 回(1 秒 ON, 25 秒 OFF)。 Rated voltage X 4 times, 10000 cyc.(1s ON, 25s OFF)</p>
端子強度 Terminal strength	<p>端子不得斷裂及鬆弛。 No evidence of mechanical damage.</p>	<p>6.1 項參照 Comply with 6.1</p> <p>引張強度：25N(2.5Kgf),保持 10 秒。 Tensile strength: 25N(2.5kgf), for 10 seconds.</p> <p>扭轉強度：360°交互迴轉 5 回。 Torsional strength: Rotated through 360°, 5 rotations.</p>



項目 Item	規格值 Performance	試驗方法 (依據 JIS C 5202) Test methods (Conform to JIS C 5202)
焊錫耐熱性 Resistance to soldering heat	±(2%+0.05Ω)以內。 不得有機械的損傷。 within ±(2%+0.05Ω) No evidence of mechanical damage.	6.4 項參照 Comply with 6.4 350±10°C, 3±0.5 秒 或 260±5°C, 10±1 秒, 試驗後放置 3 小時。 350±10°C, 3±0.5s or 260±5°C, 10±1s, After test leave for 3h.
焊錫附著性 Solderability	導線至少 95%以上新錫覆蓋。 Covered with new solder by 95% at least.	6.5 項參照 Comply with 6.5 焊錫溫度：245±5°C。 浸錫時間：5±0.5 秒。 Test temperature of solder: 245±5°C Dipping time in solder: 5±0.5s
溫度循環 Temperature cycle	±(2%+0.05Ω)以內。 不得有機械的損傷。 within ±(2%+0.05Ω) No evidence of mechanical damage.	7.4 項參照 Comply with 7.4 低溫側：-55±3°C：30 分鐘, 室溫：2~3 分鐘 高溫側：+155±2°C：30 分鐘, 室溫：2~3 分鐘 5 回 Low side：-55±3°C：30min, Room temp.：2 to 3min High side：+155±2°C：30min, Room temp.：2 to 3min 5 cycles
耐濕負荷壽命 Load life in humidity	±(5%+0.05Ω)以內。 within ±(5%+0.05Ω)	7.9 項參照 Comply with 7.9 40±2°C, 濕度 90~95%, 1000 小時 定格電壓(90 分鐘 ON, 30 分鐘 OFF) 40±2°C, 90 to 95%RH, 1000h Rated voltage (90 min ON, 30 min OFF)
負荷壽命 Load life	±(5%+0.05Ω)以內。 within ±(5%+0.05Ω)	7.10 項參照 Comply with 7.10 70±3°C, 1000 小時 定格電壓(90 分鐘 ON, 30 分鐘 OFF) 70±3°C, 1000h Rated voltage (90 min ON, 30 min OFF)
難燃性 Flammability	沒有出現火災。 No evidence of flame.	7.12 項參照 Comply with 7.12 加 4 倍,8 倍,16 倍,32 倍額定電力 AC 電壓 1 分鐘 至斷線(或相對試驗前電阻值之變化率超過 100 倍)為止。 但負荷電壓不超過最高使用電壓的 4 倍 AC voltage of 4, 8, 16 and 32 times the power rating shall be applied for 1 min. each time until disconnection occurs(or the change rate is 100 times more than the one before test.). However the applied voltage shall not exceed the value of 4 times of the maximum operating voltage.



4. 外形寸法及電阻值範圍 External dimensions & Resistance range
4.1 SQM Type (Radial Leded Type)

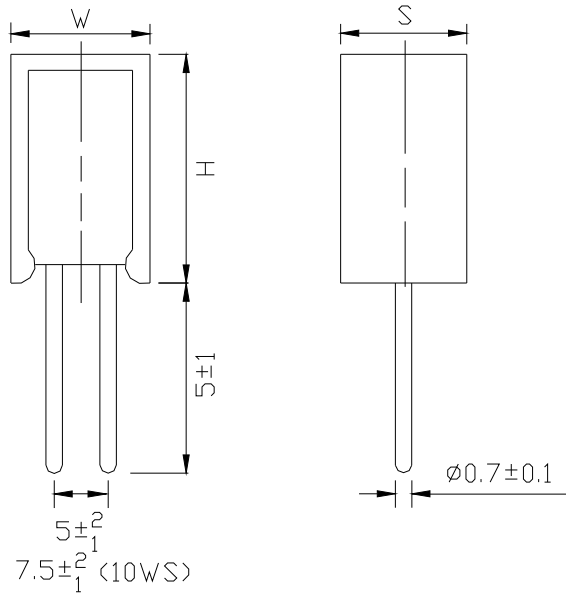

種類 Type	尺寸 Dimensions (mm)			電阻值範圍 Resistance range (Ω)	
	W±1	H±1	S±1	Wire wound	Power film
2W	11	20	7	0.1~82	83~10K
3W	12	25	8	0.1~150	151~50K
5W	13	25	9	0.1~150	151~50K
7W	13	39	9	0.1~430	431~50K
10W	13	51	9	0.1~470	471~75K
10WS	16	35	12	0.1~300	301~100K